

DRINKS | Drink Cabinets

DRINK COOLER ► UPRIGHT COOLERS

RCF 85

CUSTOMIZATION AVAILABLE
PERSONALIZZAZIONE DISPONIBILE

45 mm	K4	+1°C +9°C	C ENERGY CLASS	CC2	+32°C 65RH
LED	Key	Water	Compressor	Fan	GAS R600a

DETAILS

	
Inner assistance fan	Lock fitted as standard



GENERAL FEATURES

- 85 Lt. Upright drink cooler
- External in white coated plate, white thermoformed internally
- Roll-bond evaporator system with fan assisted cooling
- Manual Defrost
- Foaming Agent Cyclopentane (45mm per side)
- Removable Gasket
- Independent switch for internal light
- Double layer safety tempered glass
- Digital thermometer
- Reversible door
- Lock fitted as standard
- Adjustable shelves (White Color): 3 Pcs
- N.4 Adjustable feet
- Energy efficiency class: C

TECHNICAL SPECIFICATIONS

Capacity	85 L
Temperature	K4 (+1°C-+9°C)
Consumption	2.68 kWh/24h
Rated Power	65 W
Noise level	46 dB(A)
Net Weight	35 Kg
Gross Weight	38 Kg
External Dimensions (WxDxH mm)	505x590x780
Internal Dimensions (WxDxH mm)	410x395x625
Packaging dimensions (WxDxH mm)	580x620x810
Loading quantities 20'/40'/40'HQ	72/158/228

PRODUCT DIMENSIONS

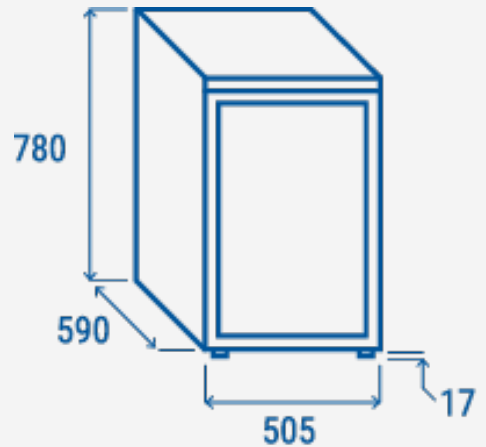

CERTIFICATION

CE RoHS

